

- NOTES:
1. OVERALL HEIGHT IS IN LOADED CONDITION. UNLOADED HEIGHTS MAY BE 4" ABOVE HEIGHTS SHOWN.
 2. DO NOT SCALE DRAWING.
 3. ALL DIMENSIONS ARE APPROXIMATE AND SUBJECT TO ENGINEERING CHANGES.
 4. DRAWING MAY OR MAY NOT SHOW ALL ITEMS AS DESCRIBED IN THE WRITTEN DETAIL SPECIFICATIONS.
 5. INCLUSION OF AN ITEM ON THE DRAWING DOES NOT CONSTITUTE INCLUSION OF THAT ITEM WITH THE FINAL DELIVERED UNIT.
 6. THE EFFECTIVE DOOR OPENINGS WILL BE APPROX. 2" LESS THAN THE NOTED COMPARTMENT OPENING FOR ROLL UP DOORS AND UP TO APPROX. 4" LESS FOR HINGED DOORS

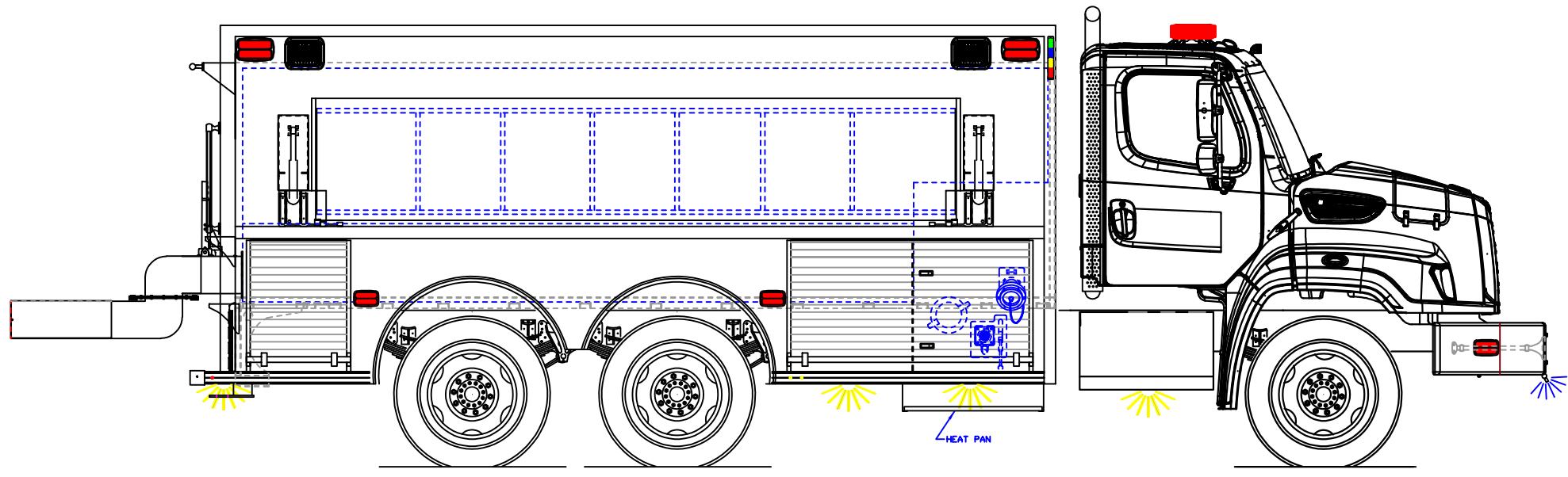
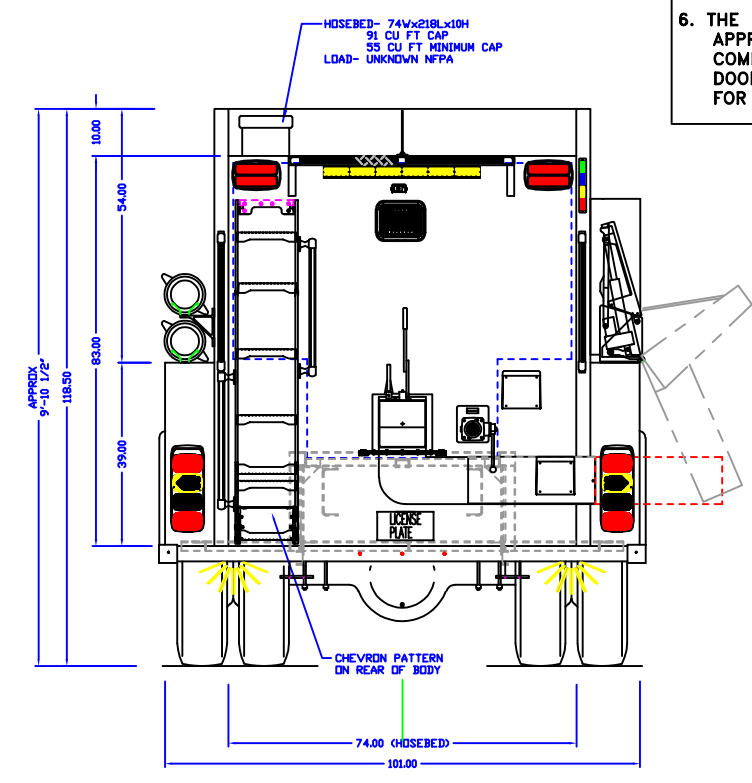
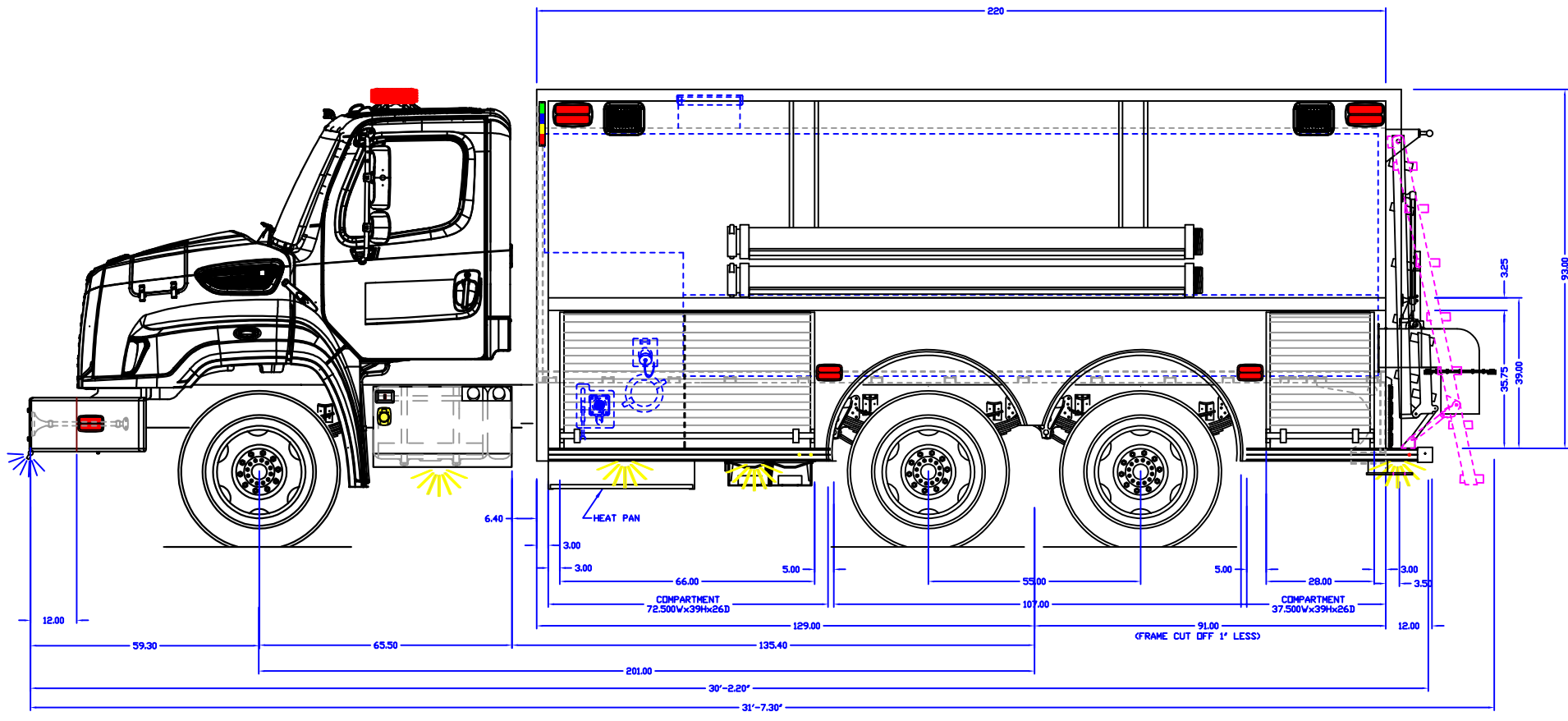

INITIALS: EH
 JOB NUMBER: 22344
 DATE: 7/17/2023

MAIN FILE: -
 DEPT: -
 DEALER: -

PRODUCTION APPROVED

APPROVED BY:

CHASSIS:	FREIGHTLINER
PUMP:	WATEROUS 500 GPM
TANK:	POLY/3000
PANEL MATL:	LINE X
COMP INTERIOR:	SPATTER PAINT

REV 1	TC	DATE: 2/14/24	
DRAWN:	MJ	DATE: 10/17/22	
PROPRIETARY AND CONFIDENTIAL THE INFORMATION CONTAINED IN THIS DRAWING IS THE SOLE PROPERTY OF ROSENBAUER. ANY REPRODUCTION IN PART OR AS A WHOLE WITHOUT THE WRITTEN PERMISSION OF ROSENBAUER IS PROHIBITED.			
MAXIMUM HEIGHT	NONE		
MAXIMUM LENGTH	NONE		
BODY WIDTH	101"		

NATRONA COUNTY FIRE PROTECTION DISTRICT, WY